

1. Description

TP4057 is an excellent linear charger with constant current and constant voltage for single lithium ion battery.

TP4057 is packaged in SOT23-6 package with less peripheral components, which makes it very suitable for portable products, and suitable for power supply of USB power supply and adapter power supply.

Based on the special internal MOSFET architecture and anti reverse charging circuit, TP4057 does not need external detection resistor and isolation diode. When the external environment temperature is too high or in high power applications, the thermal feedback can adjust the charging current to reduce the chip temperature. The charging voltage is fixed at 4.24 V, while the charging current can be set externally through a resistor. When the charging current drops to 1/10 of the set value after reaching the final floating charge voltage, the chip will terminate the charging cycle. When the input voltage is disconnected, TP4057 will enter sleep state, and the battery leakage current will drop below 1uA. The TP4057 can be set to stop mode, when the static current of the chip drops to 25uA. TP4057 also includes other features: battery temperature monitoring, undervoltage locking, automatic recharging and two status pins to show charging and charging termination.

2. Features

- Programmable charging current 500mA
- No need for external MOSFET, resistance detection and isolation diode
- Complete linear charger with SOT23-6 package for single lithium battery
- Constant current / constant voltage operation with thermal
- regulation to maximize charging rate without risk of overheating.
- The accuracy reaches 4.24V precharge voltage with accuracy of $\pm 1\%$
- Output of charging current monitor for battery power detection
- Automatic recharging
- Dual output of charging state, no battery and fault status display
- Charge termination of $C / 10$
- The static current in standby mode is 25uA
- 2.9v trickle charging
- Soft start current limiting



3.Application

- Mobile phone, PDA
- MP3 and MP4 players
- Charger
- Digital camera
- Electronic dictionary
- Bluetooth, GPS navigator
- Portable equipment
- TP4057 is packaged with SOT23-6

4.Pinning Information

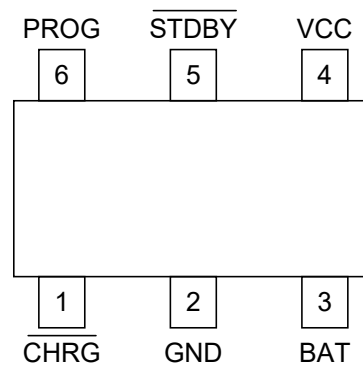

SOT23-6

Pin Description

Pin Number	Pin Name	Describe
1	$\overline{\text{CHRG}}$	Battery charging indicating terminal
2	GND	The end of the earth
3	BAT	Battery end
4	VCC	Power supply terminal
5	$\overline{\text{STDBY}}$	Battery charging completion indicator
6	PROG	Programmable constant current charging current setting terminal



5. Maximum Rating (Note)

Parameter	Rating	Units
VCC terminal voltage	-0.3 to 6.5	V
Prog terminal voltage	-0.3 to 6.5	V
Bat terminal voltage	-0.3 to 6.5	V
CHRG terminal voltage	-0.3 to 8	V
Stdby terminal voltage	-0.3 to 8	V
Bat terminal current	600	mA
Prog terminal current	800	μA
Maximum power consumption	400	mW
	800 (increase PCB heat dissipation) ⁽¹⁾	mW
Working environment temperature	-40 to 85	°C
Minimum / maximum storage temperature Tstg	-65 to 125	°C

Note (1): The addition of PCB heat dissipation parameters is for reference only.

6. ESD And Latch-up Level

ESD level of mannequin	4000V
ESD level of machine model	400V
Latch-up level	400mA



7. Structure Diagram

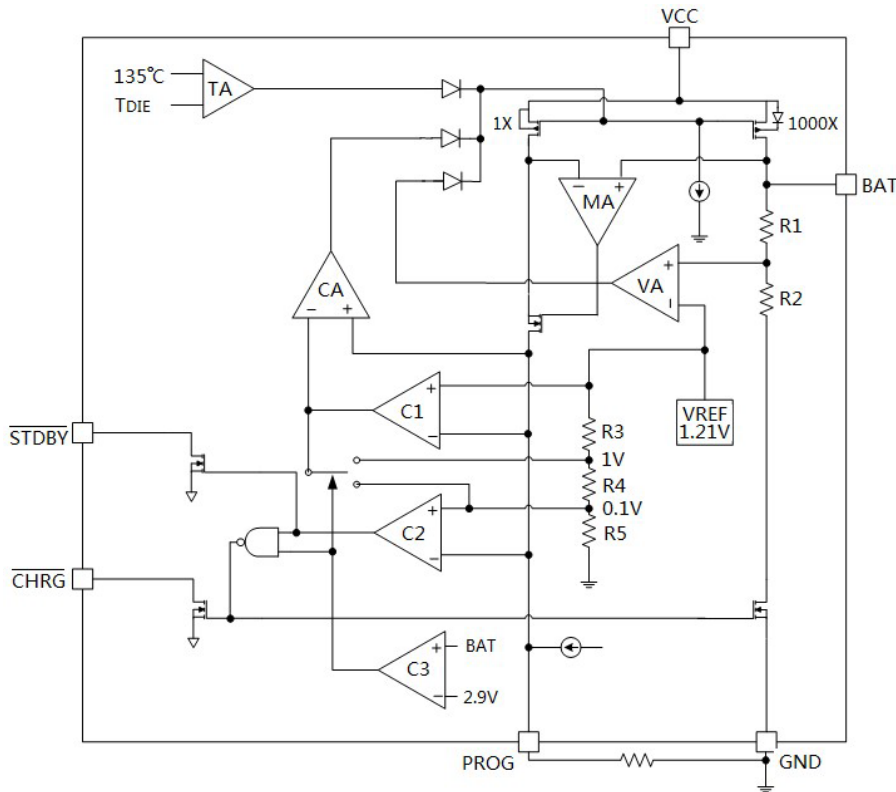

8. Typical Applications

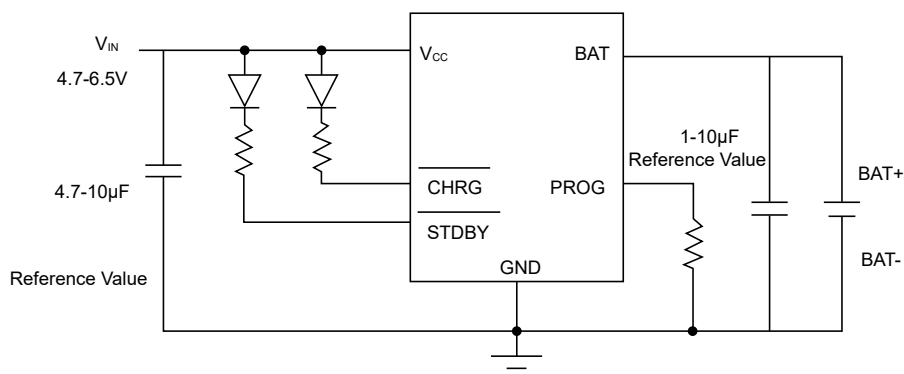



9. Electrical Characteristics

If not specified, ambient temperature = 25°C, input voltage=5V

Parameter	Symbol	Conditions	Min	Typ	Max	Units
Input Voltage	V_{CC}		4		6.5	V
Input current	I_{CC}	Charging mode ($R_{PROG}=10K$) ⁽¹⁾		240	500	μA
		Standby mode (charging termination)		45	90	μA
		Shutdown mode (R_{PROG} not connected, $V_{CC}<V_{BAT}$, $V_{CC}<V_{UVLO}$)		25	50	μA
Output control voltage	V_{FLOAT}	$0^{\circ}C<T_A<85^{\circ}C$, $I_{BAT}=40mA$	4.198	4.24	4.282	V
Bat terminal current	I_{BAT}	$R_{PROG}=10K$, Constant current mode	93	100	107	mA
		$R_{PROG}=2K$, Constant current mode	465	500	535	mA
		$V_{BAT}=4.2V$, standby mode	0	-2.5	-6	μA
		Stop mode		1	2	μA
		$V_{BAT}=-4V$, Battery reverse mode		0.7		mA
		$V_{CC}=0V$, sleep mode		0	1	μA
Trickle charge current	I_{TRIKL}	$V_{BAT}<V_{TRIKL}$, $R_{PROG}=2K$	40	50	60	mA
Trickle charging limit voltage	V_{TRIKL}	V_{BAT} up	2.7	2.9	3.1	V
Trickle charge hysteresis voltage	V_{TRHYS}	V_{BAT} decreased	60	80	100	mV
VCC undervoltage locking voltage	V_{UVLO}	V_{CC} rises	3.6	3.8	4	V
VCC undervoltage locking hysteresis voltage	V_{UVHYS}	V_{CC} decreased	150	200	300	mV
Manual turn off threshold voltage	V_{MSD}	V_{PROG} up	1.15	1.21	1.3	V
		V_{PROG} decreased	0.9	1	1.1	V
VCC - Vbat locking voltage	V_{ASD}	V_{CC} rises	70	100	140	mV
		V_{CC} decreased	5	30	50	mV
Termination current threshold (m222) ⁽²⁾	I_{TERM}	$R_{PROG}=10K$	0.085	0.1	0.115	mA
		$R_{PROG}=2K$	0.085	0.1	0.115	mA
Prog pin voltage	V_{PROG}	Constant current mode, $R_{PROG}=10K$	0.93	1	1.07	V



Parameter	Symbol	Conditions	Min	Typ	Max	Units
CHRG output low level	V_{CHRG}	$I_{\text{CHRG}}=5\text{mA}$		0.35	0.6	V
Stdby output low level	V_{STDBY}	$I_{\text{STDBY}}=5\text{mA}$		0.35	0.6	V
Threshold voltage of rechargeable battery	ΔV_{RECHG}	$V_{\text{FLOAT}} - V_{\text{RECHG}}$		100	200	mV
Recharging delay time	t_{RECHG}	V_{BAT} from high to low	0.8	1.8	4	ms
Charging termination delay time	t_{TERM}	I_{BAT} drops below $I_{\text{CHG}} / 10$	0.63	1.4	3	ms
Pull up current at prog terminal	I_{PROG}			2		μA

Note (1): It is in charging state, $I_{\text{CC}}=I_{\text{VCC}} - I_{\text{BAT}}$.

(2) Here C / 10 termination current threshold refers to the ratio of termination current to constant current charging current.



10. Instructions

TP4057 is a linear charger specially designed for lithium-ion batteries. It uses the power MOSFET inside the chip to charge the battery at constant current / constant voltage. The charging current can be determined by external resistance programming, and the maximum charging current can reach 500 mA. TP4057 has two status indication outputs with open drain, CHRG and stbby. The power transistor circuit in the chip automatically reduces the charging current when the junction temperature of the chip exceeds 135°C. This function enables users to make full use of the chip for charging, without worrying about the chip overheating and damaging the chip or external components.

11. Working principle

When the input voltage is higher than TP4057, the input voltage can be detected. If the battery voltage is lower than 2.9V, the charger will pre charge the battery with a small current. When the battery voltage exceeds 2.9V, the charger uses constant current mode to charge the battery, and the charging current is determined by the resistance between prog terminal and GND terminal. When the battery voltage is close to 4.2V, the charging current decreases gradually and TP4057 enters constant voltage charging mode. When the charging current decreases to the charging end threshold, the charging cycle ends.

The end of charge threshold is 1 / 10 of the constant current charging current. When the battery voltage drops below the recharging threshold, a new charging cycle will start automatically. The high-precision voltage reference, error amplifier and resistance divider network ensure that the accuracy of bat modulation voltage is less than 1%, which meets the requirements of lithium-ion and lithium polymer batteries. When the input voltage loses power or the input voltage is lower than the battery voltage, the charger enters the shutdown mode, and the current consumed by the battery terminal is less than 2 μ A, thus increasing the standby time.

12. Charging Termination

When the charging current drops to 1 / 10 of the set value after reaching the final floating charge voltage, the charging cycle is terminated. This condition is detected by using an internal filter comparator to monitor the prog terminal. When the prog terminal voltage drops below 100mV for more than 1.8ms, the charging is terminated and TP4057 enters the standby mode. At this time, the input power supply current drops to about 45 μ A.



When charging, the transient load on bat terminal will make the voltage of prog terminal drop below 100mV when DC charging current drops to 1 / 10 of the set value. The 1.8ms delay time of comparator ensures that transient load of this nature will not lead to premature termination of charging cycle. Once the average charging current falls below 1 / 10 of the set value, the TP4057 centralized charging cycle stops providing any current through the bat terminal. In this state, all loads on the bat end must be powered by batteries.

13. Charging Status Indication

TP4057 has two drain open state indication outputs CHRG and stdby. When the charger is in charging state, CHRG is pulled to low level, and in other states, CHRG is in high resistance state; When the battery charging is finished, the stdby is pulled to the low level. In other states, the stdby is in the high resistance state.

When the battery is not connected to the charger, CHRG flashes to indicate that no battery is installed.

State of charge	CHRG	STDBY
Charging	bright	Extinguish
Charging complete	Extinguish	bright
Bat end connected with 1uF capacitor, no battery	Flicker (frequency about 20Hz)	bright

14. Thermal limits

An internal thermal feedback loop will reduce the set charging current if the chip temperature rises above 135°C. This function prevents the TP4057 from overheating and allows users to increase the upper limit of the power processing capacity of a given circuit board and reduce the risk of damage to the tp4057



15.Under Voltage Locking

TP4057 has an internal undervoltage locking circuit to monitor the input voltage and keep the chip in shutdown mode before the VCC rises to the under voltage locking threshold voltage. When the VCC voltage increases to 3.8V, the chip exits UVLO and starts to work normally. The UVLO hysteresis voltage is 200mV when the VCC drops.

16. Automatic Charging Cycle

When the battery voltage reaches the floating charge voltage, TP4057 monitors the bat terminal voltage immediately after the charging cycle is terminated. When the bat terminal voltage is lower than 4.1V, the charging cycle starts again. It ensures that the battery is maintained in a state of near full charge, and eliminates the need for periodic charging cycle start-up.



17.SOT23-6 Package Outline Dimensions

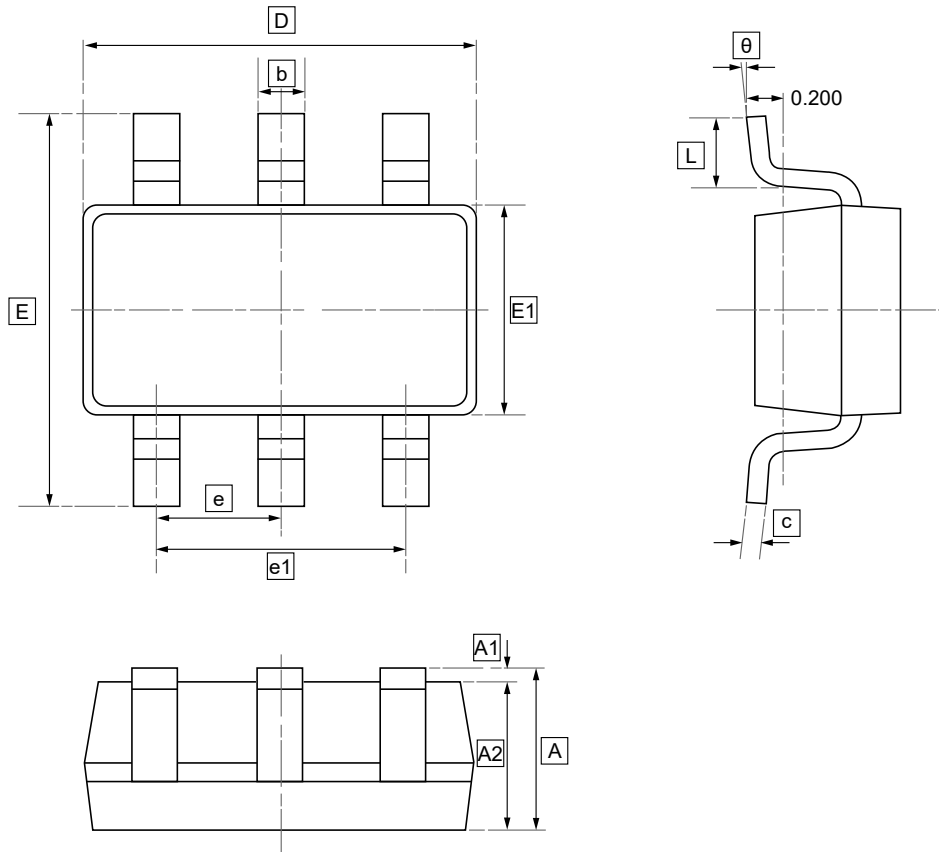

DIMENSIONS (mm are the original dimensions)

Symbol	A	A1	A2	b	c	D	E1	E	e	e1	L	θ
Min	1.050	0.000	1.050	0.300	0.100	2.820	1.500	2.650	0.950	1.800	0.300	0°
Max	1.250	0.100	1.150	0.500	0.200	3.020	1.700	2.950	BSC	2.000	0.600	8°



18. Ordering Information

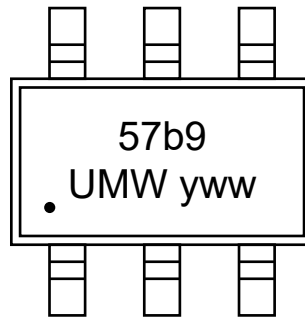

yww: Batch Code

Order Code	Package	Base QTY	Delivery Mode
UMW TP4057	SOT23-6	3000	Tape and reel



19.Disclaimer

UMW reserves the right to make changes to all products, specifications. Customers should obtain the latest version of product documentation and verify the completeness and currency of the information before placing an order.

When applying our products, please do not exceed the maximum rated values, as this may affect the reliability of the entire system. Under certain conditions, any semiconductor product may experience faults or failures. Buyers are responsible for adhering to safety standards and implementing safety measures during system design, prototyping, and manufacturing when using our products to prevent potential failure risks that could lead to personal injury or property damage.

Unless explicitly stated in writing, UMW products are not intended for use in medical, life-saving, or life-sustaining applications, nor for any other applications where product failure could result in personal injury or death. If customers use or sell the product for such applications without explicit authorization, they assume all associated risks.

When reselling, applying, or exporting, please comply with export control laws and regulations of China, the United States, the United Kingdom, the European Union, and other relevant countries, regions, and international organizations.

This document and any actions by UMW do not grant any intellectual property rights, whether express or implied, by estoppel or otherwise. The product names and marks mentioned herein may be trademarks of their respective owners.